	DOC NO	MODEL	NAME	REV.	PAGE
	PL-VCDM0000-005	VCDM	User Manual	1.2	1 of 15

# User Manual

MODEL : VCDM  
REV. : 1.2  
DATE : 2017. 06. 21



**PULOON Technology Inc.**

	<b>DOC NO</b>	<b>MODEL</b>	<b>NAME</b>	<b>REV.</b>	<b>PAGE</b>
	PL-VCDM0000-005	VCDM	User Manual	1.2	2 of 15

## Revision History

Ver.	DATE	Item		Name
		Title	Details	
1.0	2009.10.30	Released		H.J.KIM
1.1	2010.09.09	Update Pictures		Y.J.LEE
1.2	2017.06.21	Removal of cassette		Serene Kim

	DOC NO	MODEL	NAME	REV.	PAGE
	PL-VCDM0000-005	VCDM	User Manual	1.2	3 of 15

## Contents

<b>1</b>	<b>PREVIEW AND FEATURES .....</b>	<b>4</b>
1.1	PREVIEW .....	4
1.2	FEATURES.....	5
<b>2</b>	<b>LOADING AND UNLOADING NOTES .....</b>	<b>6</b>
2.1	PREPARING NOTES .....	6
2.2	REMOVAL OF CASH CASSETTE AND COLLECTING REJECTED NOTES	8
2.3	NOTE LOADING .....	9
<b>3</b>	<b>TROUBLE SHOOTING.....</b>	<b>14</b>
3.1	CLEARING NOTE JAM .....	14

	DOC NO	MODEL	NAME	REV.	PAGE
	PL-VCDM0000-005	VCDM	User Manual	1.2	4 of 15

## 1 PREVIEW AND FEATURES

### 1.1 PREVIEW

VCDM is the cash-dispensing unit and its main function is to dispense the exact number of banknotes in the cassette by a customer's request and to transfer to the customer automatically.

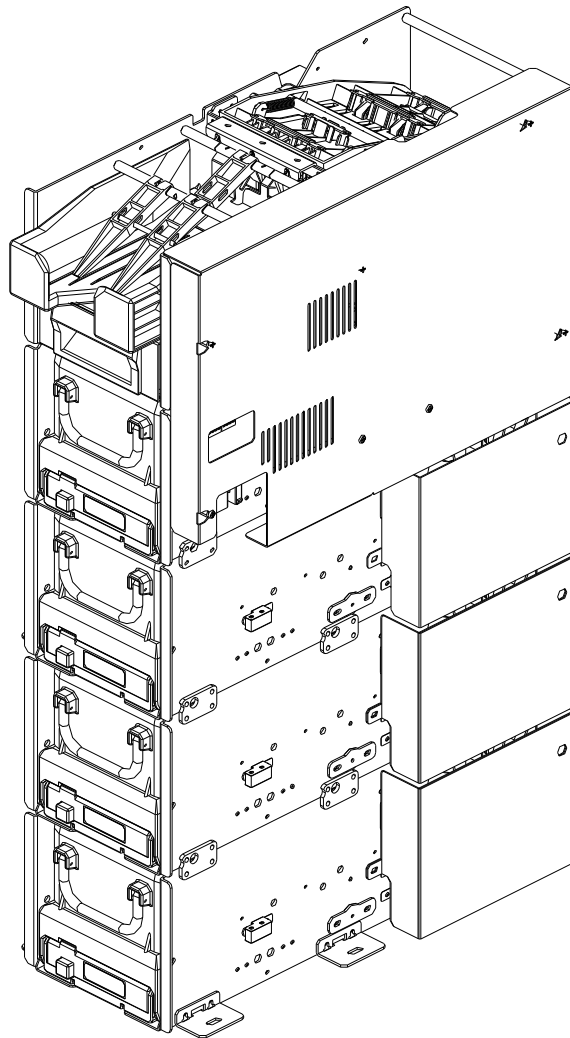

	<b>DOC NO</b>	<b>MODEL</b>	<b>NAME</b>	<b>REV.</b>	<b>PAGE</b>
	PL-VCDM0000-005	VCDM	User Manual	1.2	5 of 15

## 1.2 FEATURES

- 1) To separate notes by friction roller & plate.
- 2) To prevent from double dispensing case by ultrasonic double detect mechanism
- 3) To implement mold guides and paths to minimize jam occurrence
- 4) To maximize convenience in maintenance or clearing by opening guide structure
- 5) To realize compact and slim size so as to be applied to even small space
- 6) To speed at a rate of 3.0 notes/sec
- 7) To have tray for customer easily to take the sprayed notes
- 8) After power failure, bills on the path are rejected to reject tray when power turns on again (Auto Reject Function)

	DOC NO	MODEL	NAME	REV.	PAGE
	PL-VCDM0000-005	VCDM	User Manual	1.2	6 of 15

## 2 LOADING AND UNLOADING NOTES

### 2.1 PREPARING NOTES

The number of rejects depends directly on the loading procedure and the quality of the notes. Store the notes at room temperature for at least eight hours before feeding from cash cassette. The following procedures are recommended to aid easier note feeding from trays.

Without preparation, feeding problems may occur, such as a higher reject rate or jams in the cash transport path.

#### ① New, unused notes

Remove the band around each bundle of notes.

Separate the notes from each other by:

- Striking the bundle hard against the edge of a table or similar object.
- Flipping the rough each bundle of notes in both directions at both ends.
- Using a note counter.

Select notes from the centre of the bundle. The notes in the centre are normally flat, notes in the ends of the bundle are often cupped.

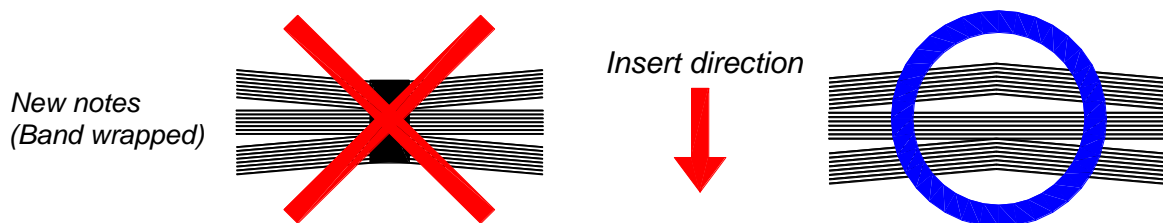

#### ② Unacceptable notes

Notes with the following irregularities are liable to cause feeding problems

- Joined by any means
- Having staples or pins
- Sticky surfaces
- Repaired with tape

	DOC NO	MODEL	NAME	REV.	PAGE
	PL-VCDM0000-005	VCDM	User Manual	1.2	7 of 15

- Torn, with tears exceeding 5mm or with centre edged tears
- Having holes or missing sections
- Crumpled or crisp and crinckled
- Dog-eared, with a folded edge exceeding 5mm
- Limp or moist
- Concave or deformed by prolonged storage
- Having strapping damage
- Combination of new and used notes in the same cassette may cause higher reject rates.

### ③ Used notes

Used Notes must not be limp and should be reasonably clean.

- Remove the band around each bundle of notes.
- Remove foreign objects, e.g. pins, paper clips etc.
- Remove torn or very worn notes.
- Straighten any folded notes.

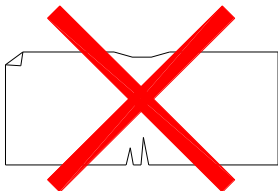

→ Dog-eared, strapping damage, center edge tears

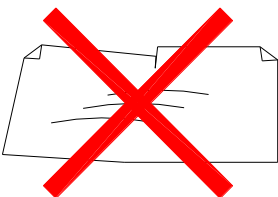

→ Crumpled

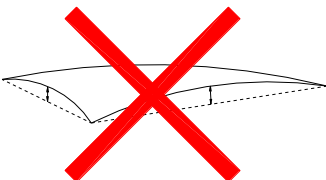

→ Concaved (Height: 5 mm or more)

	DOC NO	MODEL	NAME	REV.	PAGE
	PL-VCDM0000-005	VCDM	User Manual	1.2	8 of 15

## 2.2 REMOVAL OF CASH CASSETTE AND COLLECTING REJECTED NOTES

The cash cassette can only be removed when the machine is NOT in operation. Please do not take out the cassette while the machine is running. If the cassette is removed during operation, it might cause a problem to the dispenser.

### ① Remove the cash cassette

- Grip the handle and push lock button, and pull cash cassette out.



### ② Collect rejected notes

- Collect rejected notes from the reject compartment part of the reject tray as shown.





	DOC NO	MODEL	NAME	REV.	PAGE
	PL-VCDM0000-005	VCDM	User Manual	1.2	9 of 15

### 2.3 NOTE LOADING

Load only notes of the correct denomination into the VCDM cash cassette.

① **Open the cover top and move the pusher plate & the rear pusher**

- The pusher plate has to be moved to give space for the notes between the pusher plate and the feed opening.

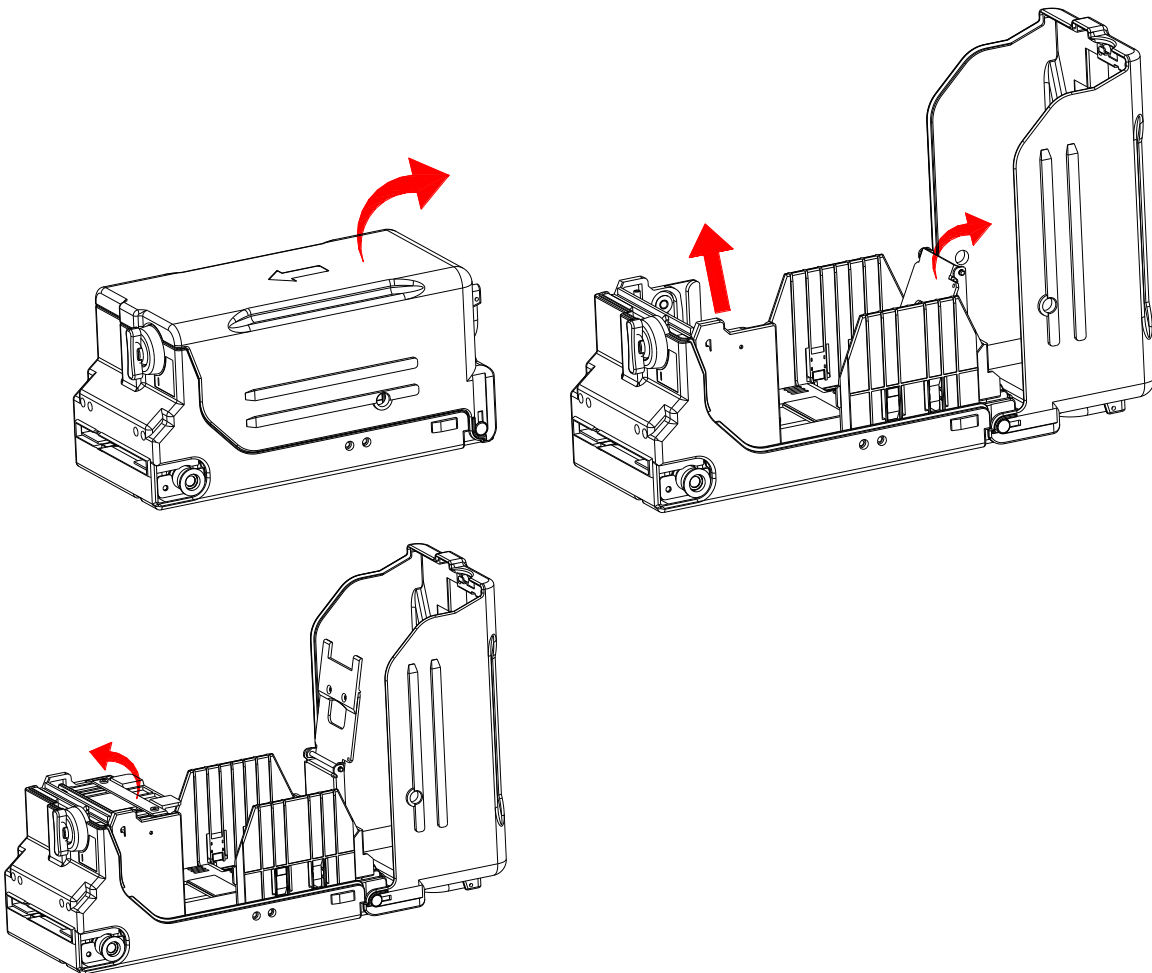

	DOC NO	MODEL	NAME	REV.	PAGE
	PL-VCDM0000-005	VCDM	User Manual	1.2	10 of 15

② Prepare and load the notes

**[Warning]**

- Notes are sometimes thicker in certain parts. They can also be cupped in the bundle.
- If the notes are turned the same way, the pile will be unequal and the notes will be difficult to dispense.

**- Slanting pile**

: To avoid dispensing problems caused by a slanting pile, put the notes in neat bundles of 100-200 notes.

: Turn every othe bundle to face the ogher way to make the pile the same height at both sides.

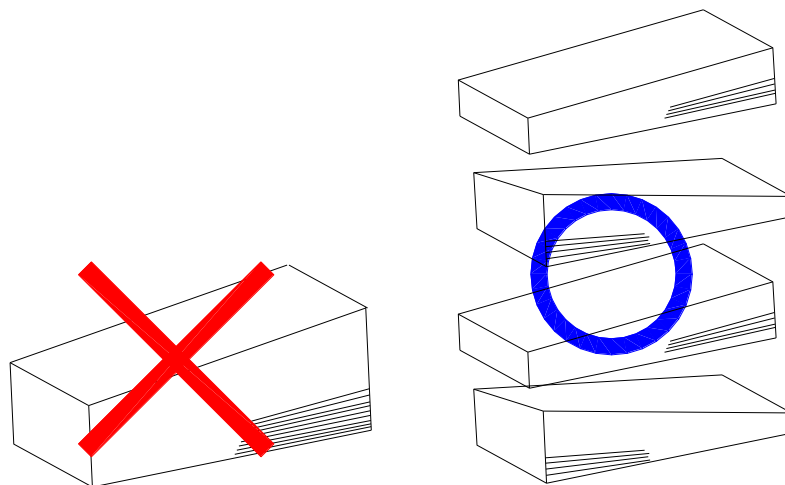

**- Bad aligned bundle**

: To avoid dispensing problems caused by bad aligning of note bundles, must be aligned the front side of bundles.

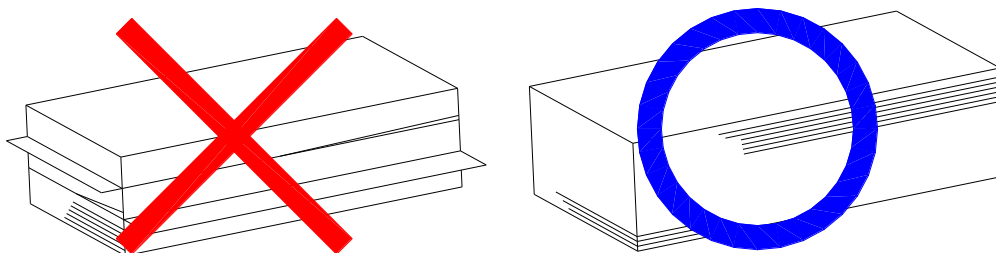

	DOC NO	MODEL	NAME	REV.	PAGE
	PL-VCDM0000-005	VCDM	User Manual	1.2	11 of 15

**- Concave bundle**

: To avoid dispensing problems caused by cupped bundles, turn all the bundles with the cupped side towards the dispense opening.

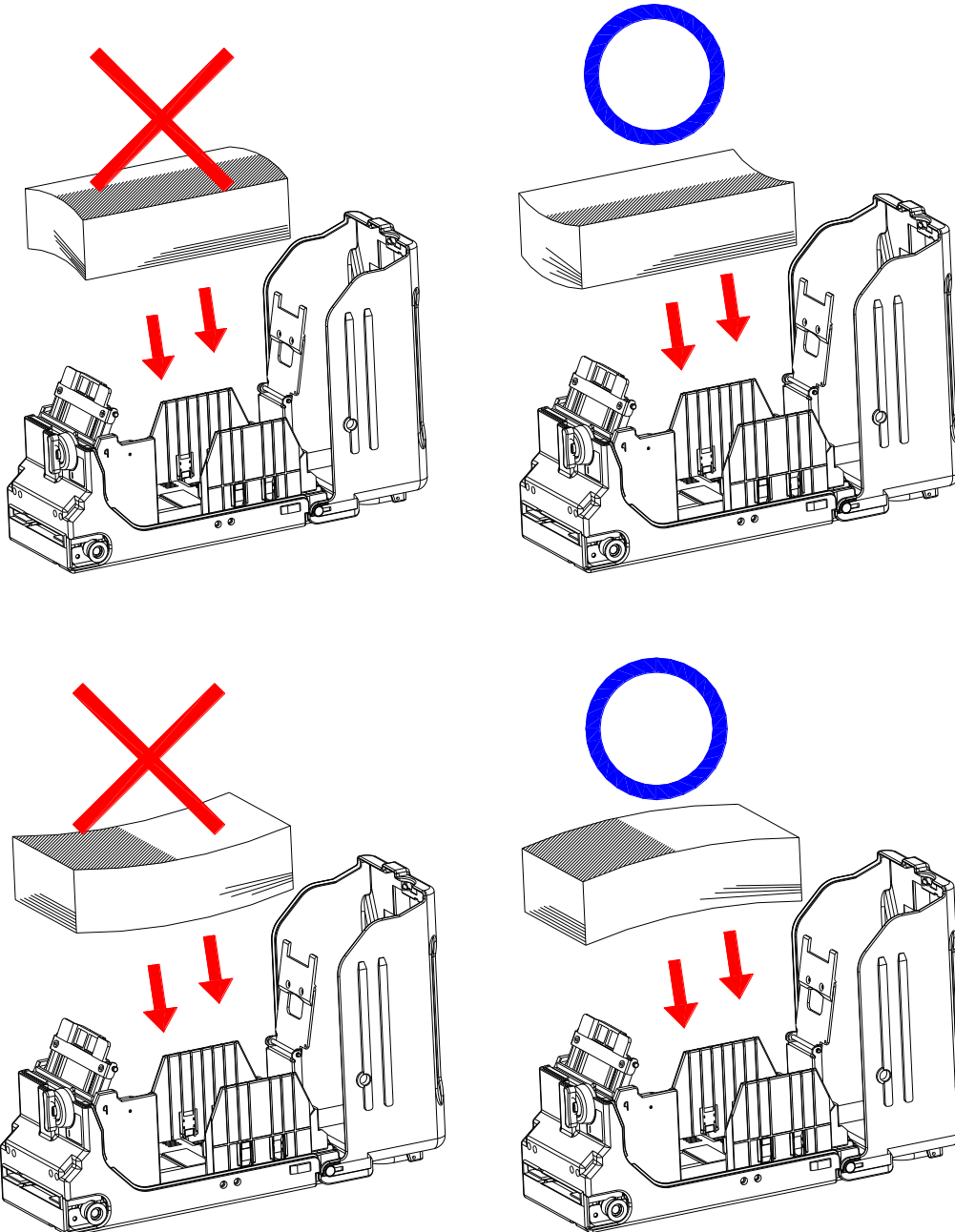

	DOC NO	MODEL	NAME	REV.	PAGE
	PL-VCDM0000-005	VCDM	User Manual	1.2	12 of 15

- Mixed slanting and concave bundles

: To avoid dispensing problems caused by a slanting and cupped bundles, put the notes in neat bundles of 100-200 notes.

: Place the prepared bundles with the cupped side nearest and towards the dispense opening.

: Turn every other bundle to face the other way to make the pile the same height at both sides, as shown. It will make dispensing of notes from the VCDM easier.

: Always place the bundles containing old notes into the cassette first and bundles containing new notes last.

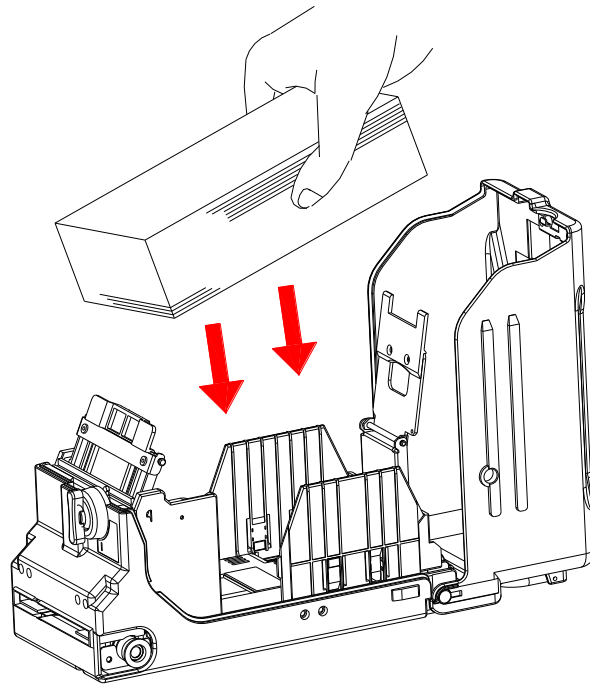

**③ Release the pusher plate**

- Release the pusher plate towards the note pile.

**④ Side aligning the pile**

- Aligning the note pile by hand. Single note must not protrude from the bundle.

	DOC NO	MODEL	NAME	REV.	PAGE
	PL-VCDM0000-005	VCDM	User Manual	1.2	13 of 15

**[Note]**

When loading the cash cassette full, make sure that the pusher plate don't exceed rear side guide. (Maximum loading limit)

If the pusher plate exceed rear side guide, the notes will be difficult to dispense.

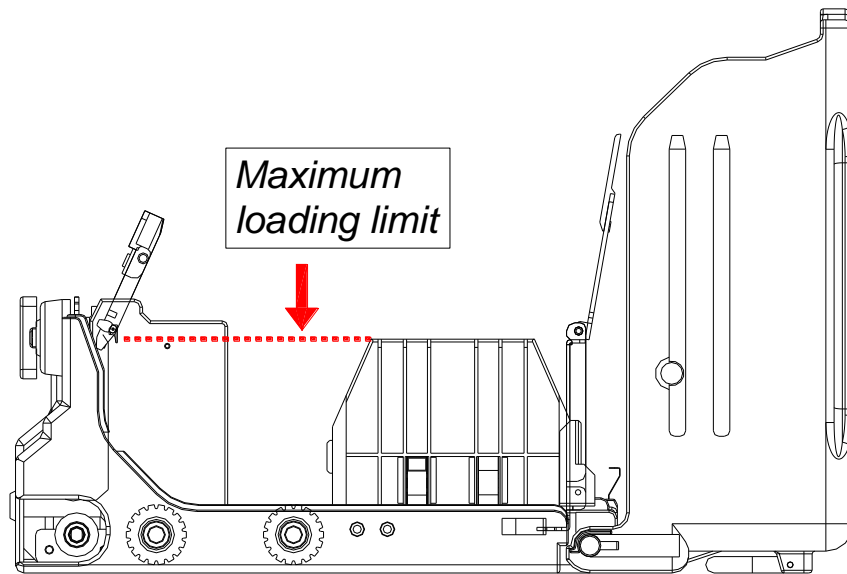

**⑤ Insert the cash cassette**

- Using the handle, slide the cash cassette into the machine.
- Make sure the cash cassette is fully inserted.
  
- The VCDM is now ready to execute commands from host or application.

	DOC NO	MODEL	NAME	REV.	PAGE
	PL-VCDM0000-005	VCDM	User Manual	1.2	14 of 15

### 3 TROUBLE SHOOTING

#### 3.1 CLEARING NOTE JAM

##### ① Remove cash cassette (see page 8)

**[Important]**

- Always switch the power OFF before clearing jams.
- All notes removed from the mechanism must be handled according to local procedures.

##### ② Remove notes in the note inlet area

- Inspect the note inlet area and remove any jammed notes.

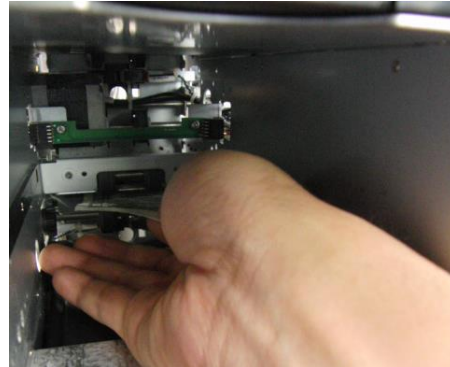

##### ③ Open the path guide and remove all jammed notes.

- Open the path guide (release the green handle), and remove any jammed notes.

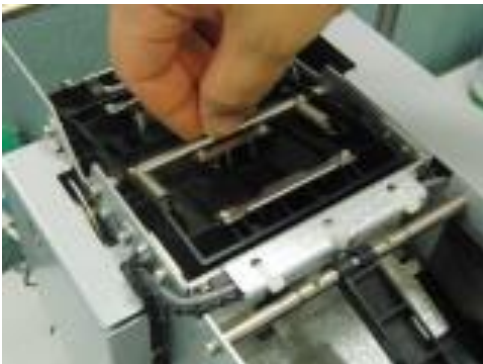

	DOC NO	MODEL	NAME	REV.	PAGE
	PL-VCDM0000-005	VCDM	User Manual	1.2	15 of 15



**④ Close the path guide**

- Make sure that you close the path guide properly.

**⑤ Remove jammed notes (using the knob)**

- Remove all visible jammed notes in the note transport by turning the knob wheel clockwise as shown.



- If the trouble still remains, call for service.